

FRONT VIEW

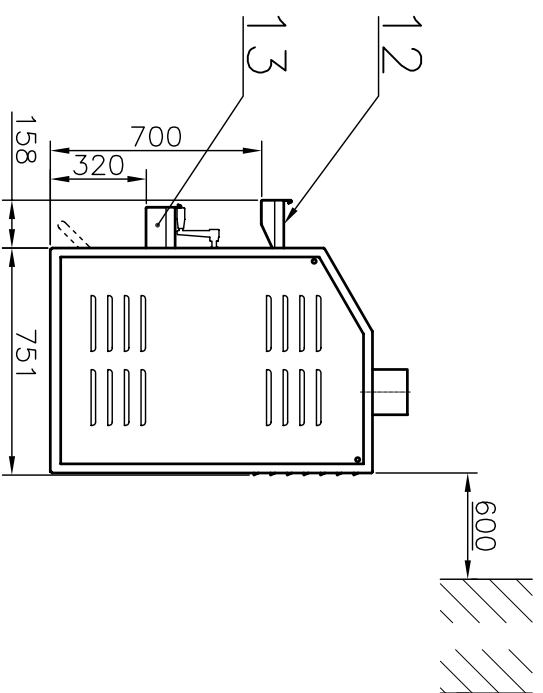

SIDE VIEW

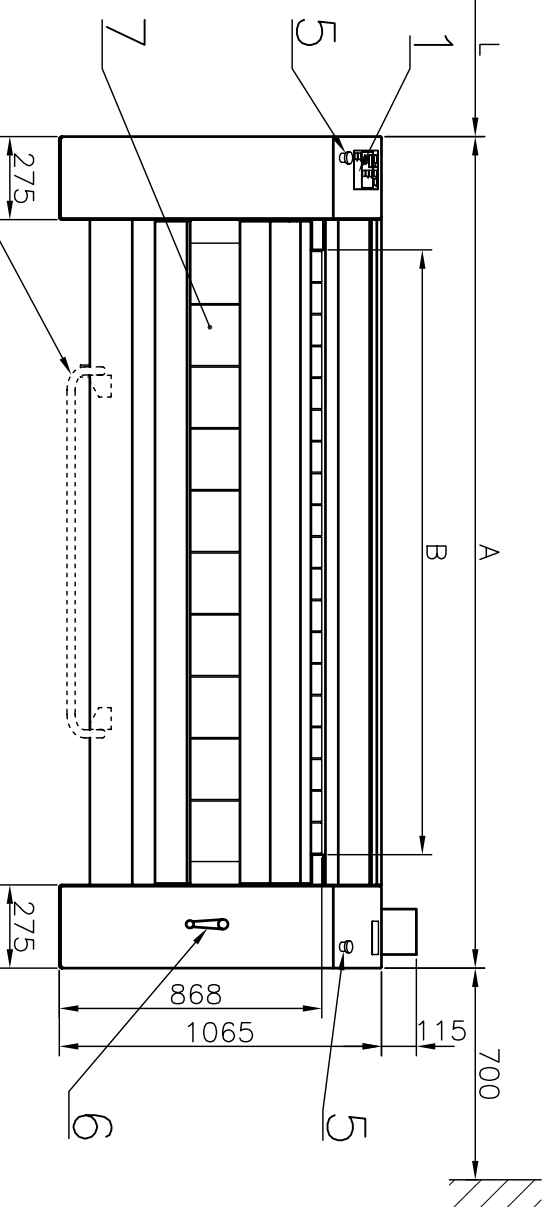

REAR VIEW

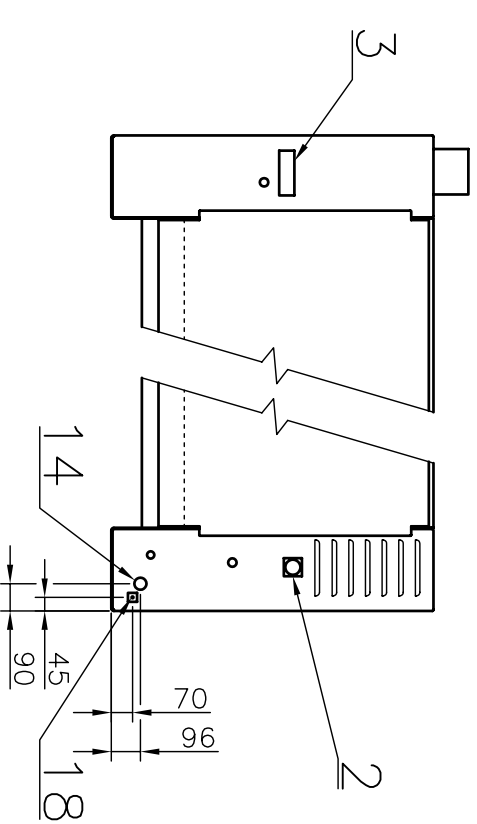

MACHINE	Distance "L" [m]
I 35-140 E	1.2
I 35-160 E	1.2
I 35-200 E	1.6

GROUND-PLAN VIEW

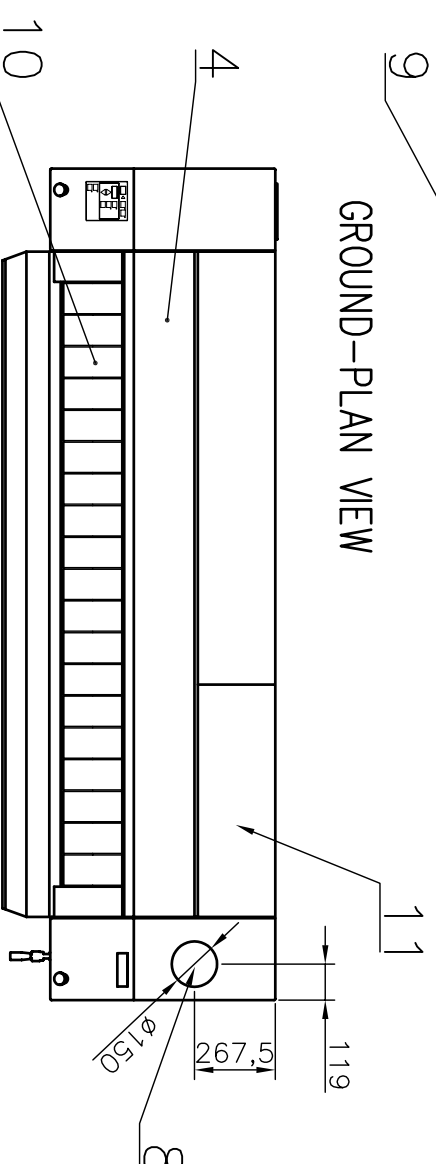

LEGEND:

1. Control panel
2. Main switch
3. Name plate
4. Upper cover
5. Emergency stop
6. Manual drive of roller
7. Ironing belts
8. Exhaust ventilation
9. Pedal used for starting/stopping belts' movement
10. Insertion belts
11. Cover of filter sieve
12. Upper trough
13. Lower trough
14. Main power supply
15. -
16. -
17. -
18. External protective connector

EXHAUST SYSTEM:

The ironer produces hot humid air (temp. 70±90°C) and combustible lint. To reduce a risk of fire the dryer must be exhausted to the outdoors by means of exhaust duct connected to exhaust piping.

The design of the flue system shall be such that any a condensate formed when operating the appliance from cold shall either be retained and subsequently re-evaporated or discharged. If possible, do not install dryers and gas fired hot water heaters or the other gravity vented appliances in the same room.

Use exhaust ducts made of sheet metal or other noncombustible material.

The ironer requires an action related to air which replaced the air exhausted from the ironer. Opening(s) for air supply from outside of the building should be as close to the machine as possible.

Aerating opening(s) for the make-up air supply required per each individual ironer is 0,13 m².

MARK	I 35-140	I 35-160	I 35-200
Maximum feeding width B	1400mm / 55"	1600mm / 63"	2000mm / 79"
Machine width - A	2150mm / 84.6"	2350mm / 92.5"	2750mm / 108.3"
Roller diameter	352mm / 13.9"	352mm / 13.9"	352mm / 13.9"
Roller length	1500mm / 59"	1700mm / 67"	2100mm / 82.7"
Ironing speed	1.5-8m/min / 5±26' /min	1.5-8m/min / 5±26' /min	1.5-8m/min / 5±26' /min
Weight netto / brutto	560kg / 710kg 1235lb / 1565lb	610kg / 780kg 1345lb / 1720lb	680kg / 880kg 1500lb / 1940lb
Air outlet	Ø150mm / Ø5"	Ø150mm / Ø5"	Ø150mm / Ø5"
Min. air flow	500 m ³ /hour	500 m ³ /hour	500 m ³ /hour
Optimum air flow	990 m ³ /hour	990 m ³ /hour	990 m ³ /hour
Max. static back pressure at pipeline	233Pa / 0.034 psi	233Pa / 0.034 psi	233Pa / 0.034 psi

ELECTRICAL DATA

Heating elements	15.9 kW	24.3 kW	27.9 kW
Drive power	0.37 kW	0.37 kW	0.37 kW
Fan power	0.18 kW	0.18 kW	0.18 kW
Voltage system	3+N+PE ~50Hz 400/230V / TN-S		
Installed load	17 kW	25 kW	29 kW
Amps	32 A	50 A	50 A
Conductor section	5x 6 mm ² Cu	5x 10 mm ² Cu	5x 10 mm ² Cu
Sound of pressure level	67.6 dB (A)	67.6 dB (A)	67.6 dB (A)

I 35 E

Datum:	03.3.03	No.	03-107-2.1
Autor:	T.R.	Index/datum	C/08.2006

CYLINDER HEATED IRONER